

# Miyano

## BNJ51

Fixed Headstock Type CNC Automatic Lathe

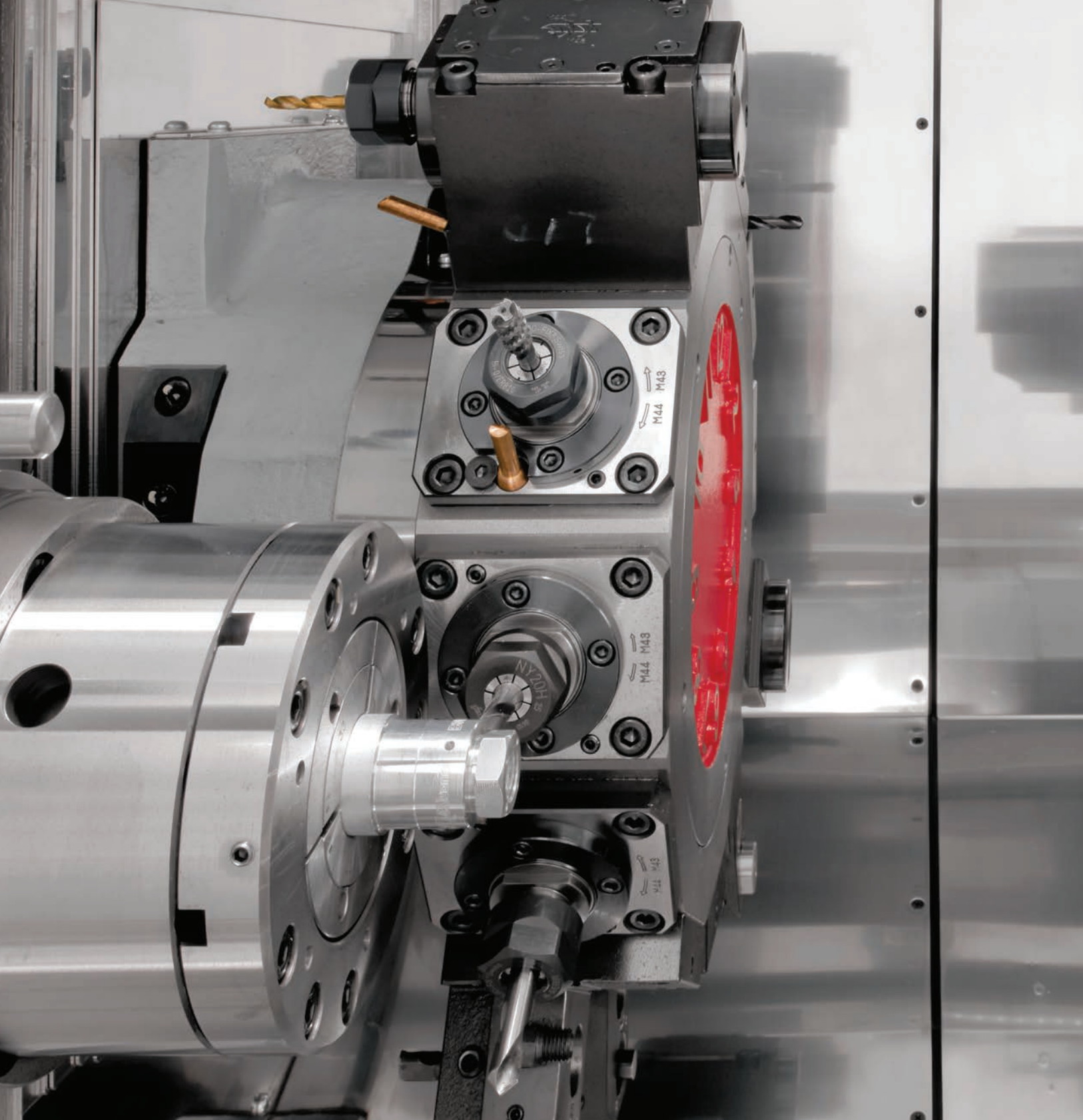



Turret No. 2 now has 8 tool mounting stations in place of the 6 on the previous machines, so the number of tools has increased and optional revolving tools can also be mounted.

The milling processes that were handled using turret No. 1 can now be shared with turret No. 2, making it possible to substantially shorten cycle times and deal with workpieces that require complex machining.



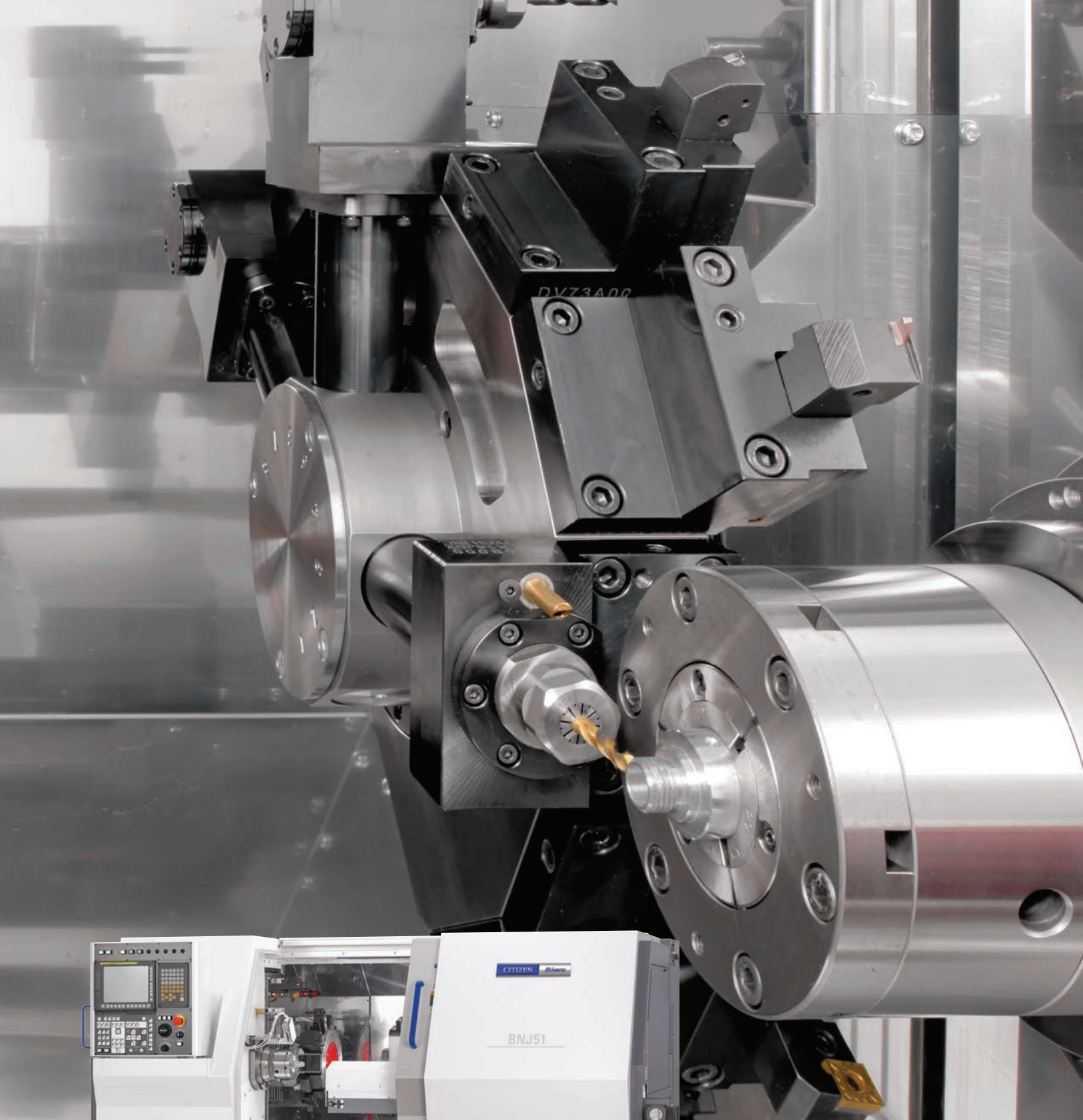

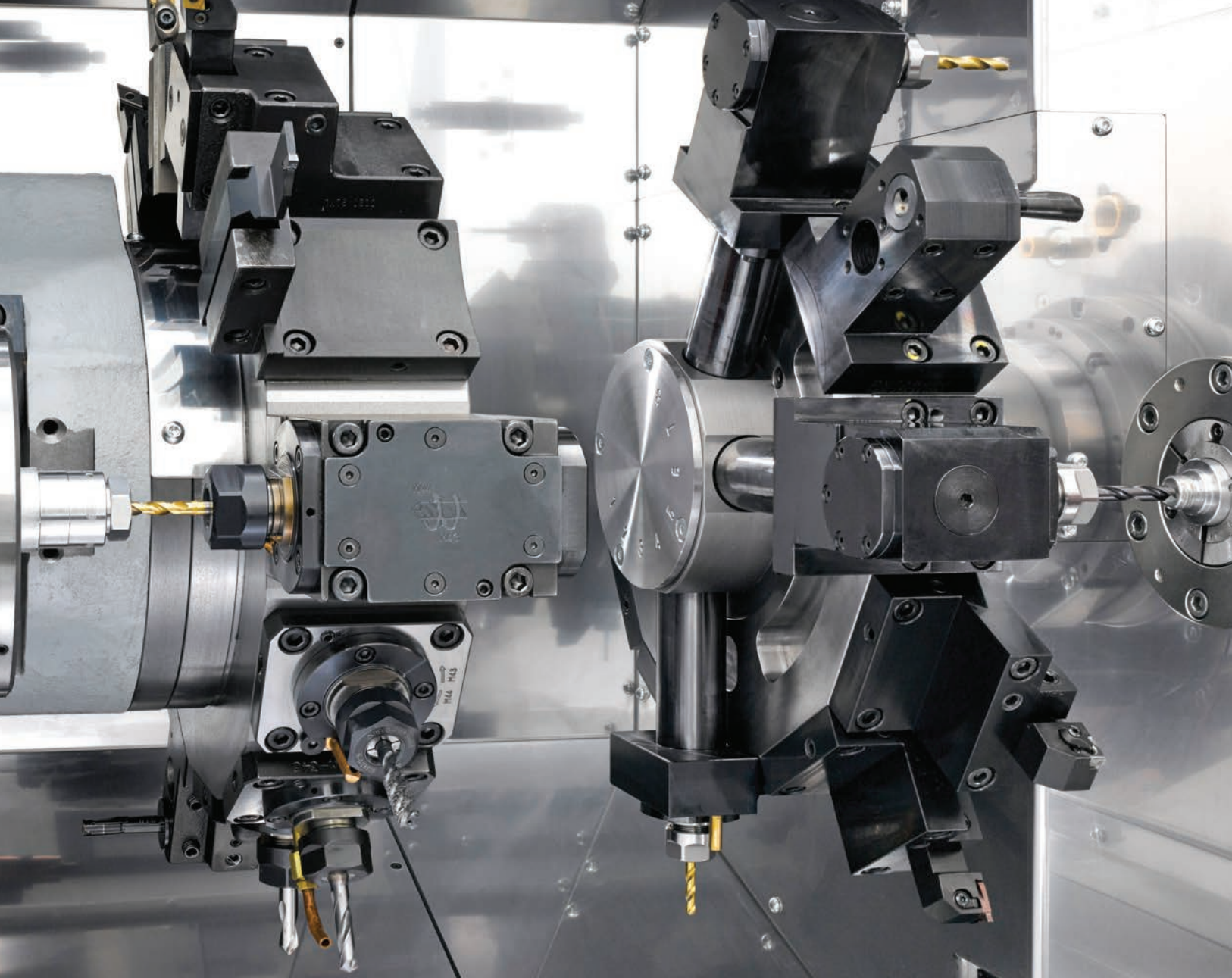

**Turret No. 1 Accommodating Higher-torque Revolving Tools**

Since a single drive mechanism is used to drive the revolving tools, they can be mounted at all stations. With a maximum torque of 25 Nm, they can handle heavy-duty cutting as well.

**Turret No. 2 Now With a Bigger Tool Capacity and Ability to Accommodate Optional Revolving Tools**

The number of tool mounting positions has increased from the six on existing machines to eight. The turret also now accepts double plain holders, greatly increasing the number of tools that can be mounted.

**Machining Time Shortened by Simultaneous Machining at Left and Right**

High efficiency is assured by having turret No. 1 and 2 machine simultaneously at left and right at spindles 1 and 2.



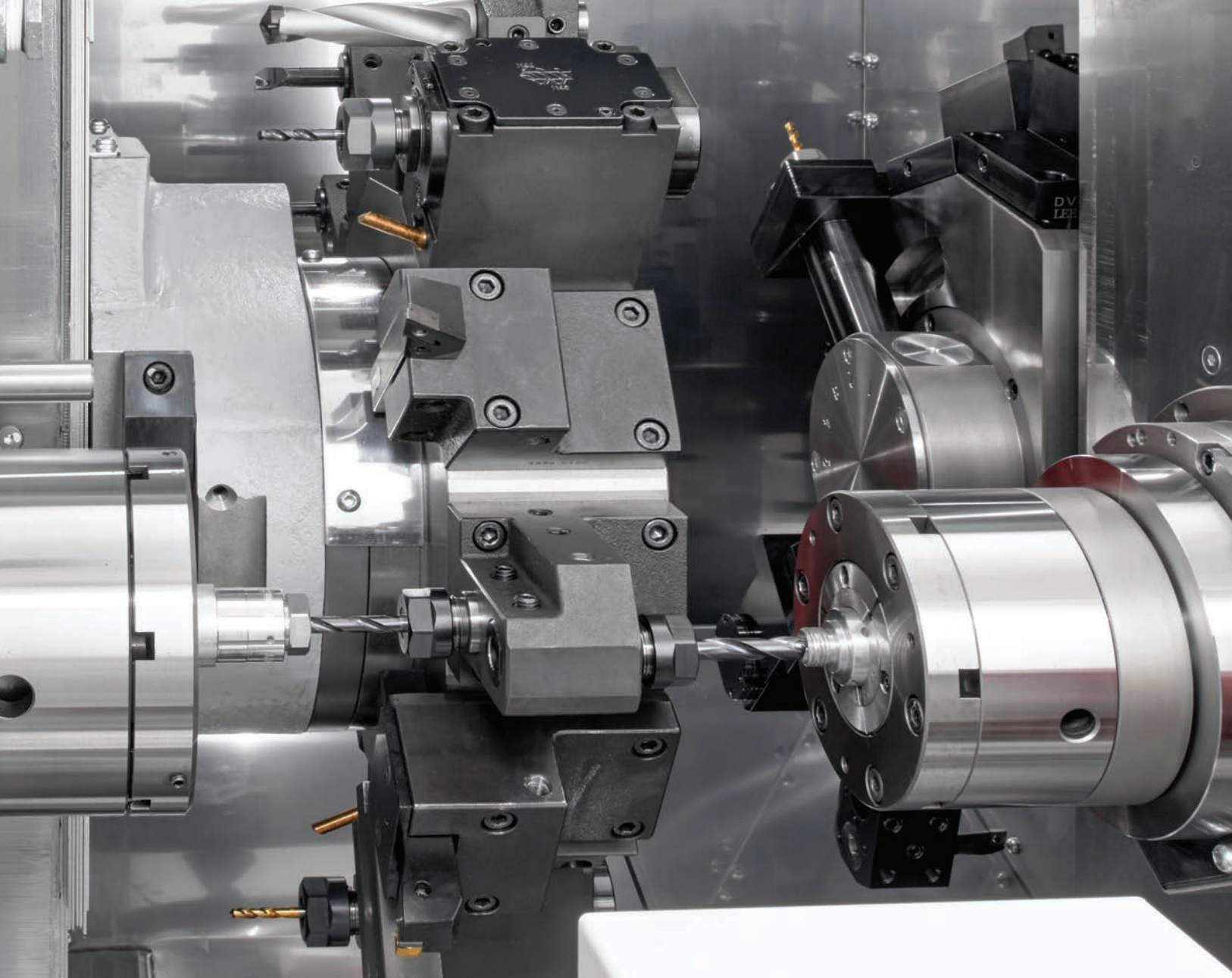

**Combined Machining with the Y-axis**

The SY type can handle the machining of complex shapes using the main turret's Y axis function.

**Machining Time Shortened through Superimposition Machining**

Superimposition control, where the move commands of turret No. 2 that can move in the X and Z directions are overlapped on the movement of turret No. 1, thus achieving substantial reductions in machining time.

# Basic Construction

## Turret No. 1

Type of turret: 12 Station  
Number of revolving tools mountable: 12 (25 Nm)

## Turret No. 2

Type of turret: 8 Station  
Number of revolving tools mountable: 4 (10 Nm)

## Spindle No. 1

Spindle speed: 5000 rpm  
Motor: 15/11 kW

## Spindle No. 2

Spindle speed: 5000 rpm  
Motor: 7.5/5.5 kW

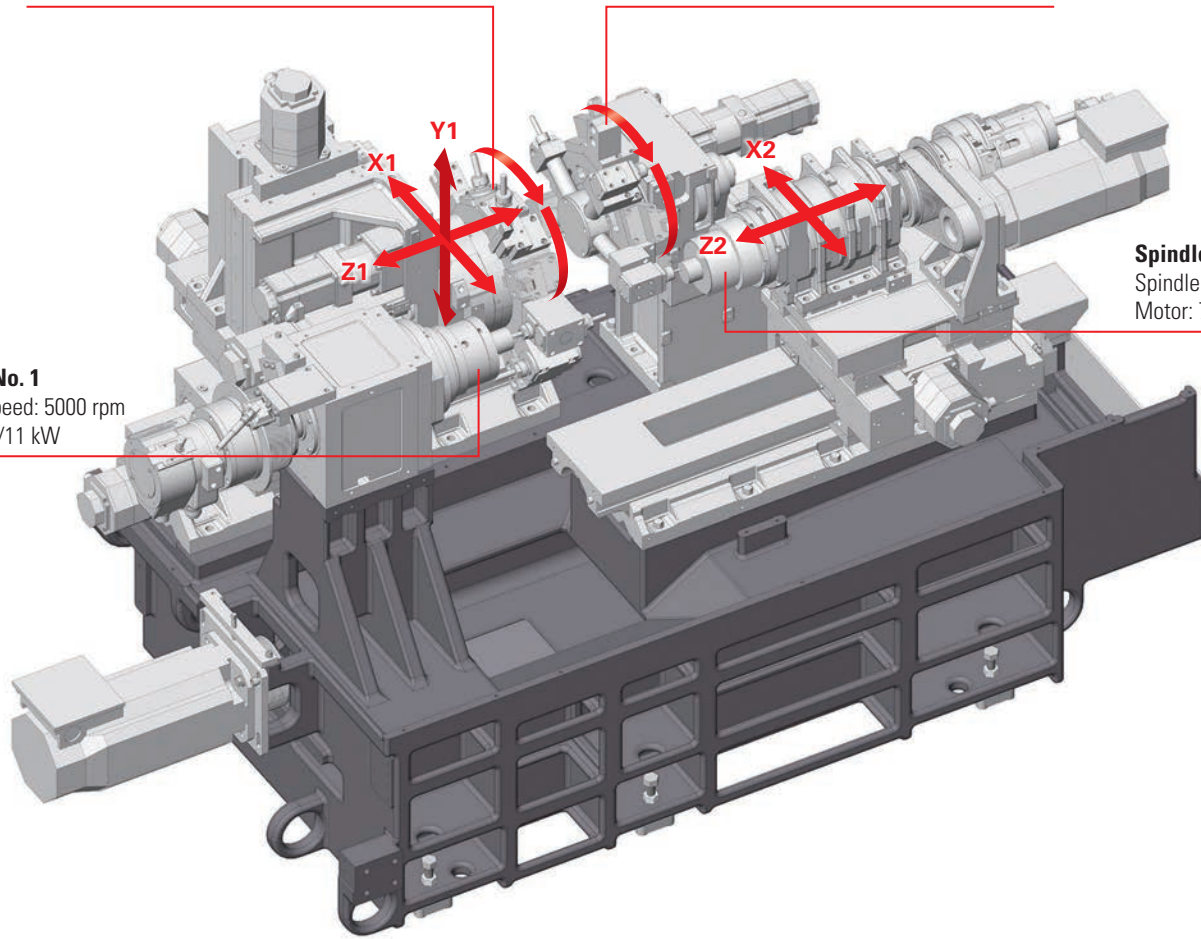

# External View

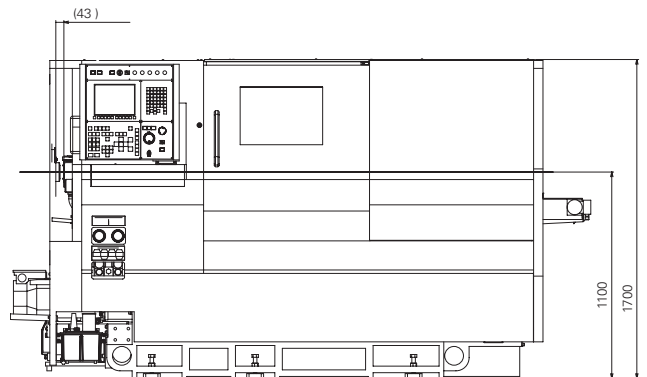
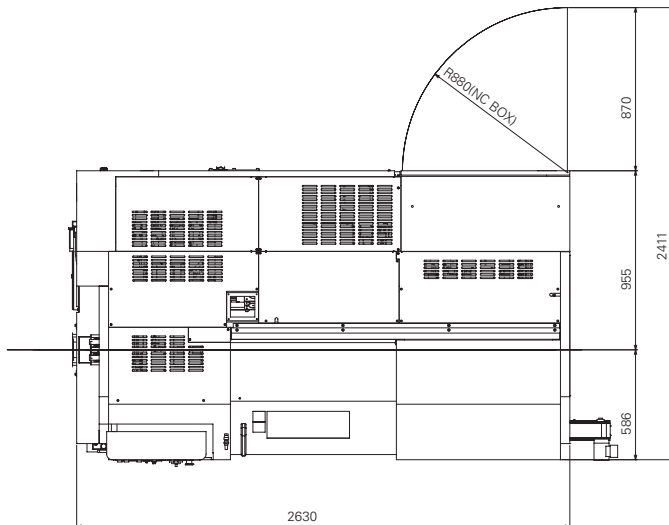

# High Rigidity Spindle and Higher Torque Revolving Tools

The BNJ-51 has further increased the rigidity of spindle 1 by adopting the combination of angular contact ball bearings and double-row cylindrical roller bearings at the front, and double-row cylindrical roller bearings at the rear.

Assembling and inspecting these spindles based on a strict management system gives them ample rigidity and suppression of abnormal heat output, and manageable thermal displacement characteristics, thus facilitating high-precision machining.

In addition, the use of rigid 25 Nm revolving tools on turret No. 1 achieves stable milling.

## Revolving Tool Torque Diagram

Turret No.1

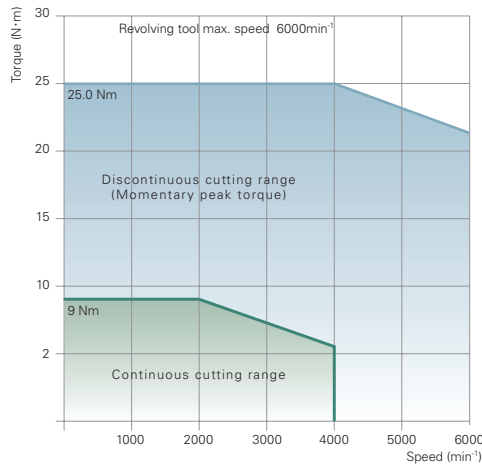

## Revolving Tool Torque Diagram

Turret No.2

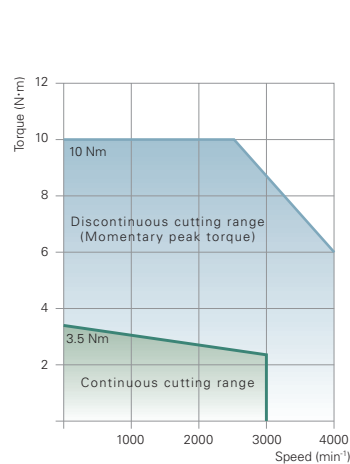

# Machining Accuracy

### Test piece

Material: BSBM (Brass)  
 Spindle speed: 3,000 rpm  
 Feed: 0.06 mm/rev  
 Depth of cut: 0.5 mm (in diameter), 0.25 mm (in radius)

Part B (HD2 & SP2)

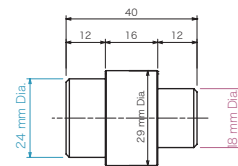

Part A (HD1 & SP1)

### Roundness (part A)

0.66 $\mu$ m

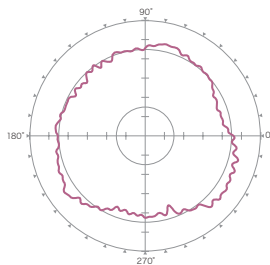

### Surface roughness (part A)

Rz 2.5468 $\mu$ m



### Roundness (part B)

0.62 $\mu$ m

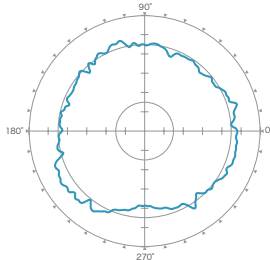

### Surface roughness (part A)

Rz 2.3419 $\mu$ m

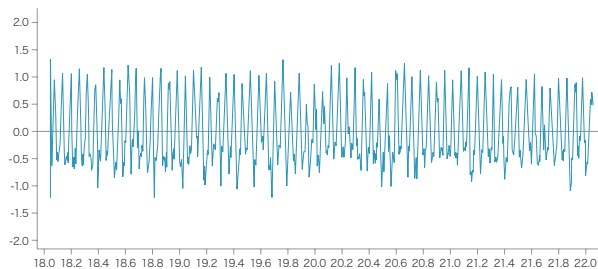

This data does not guarantee accuracy

# Tooling System

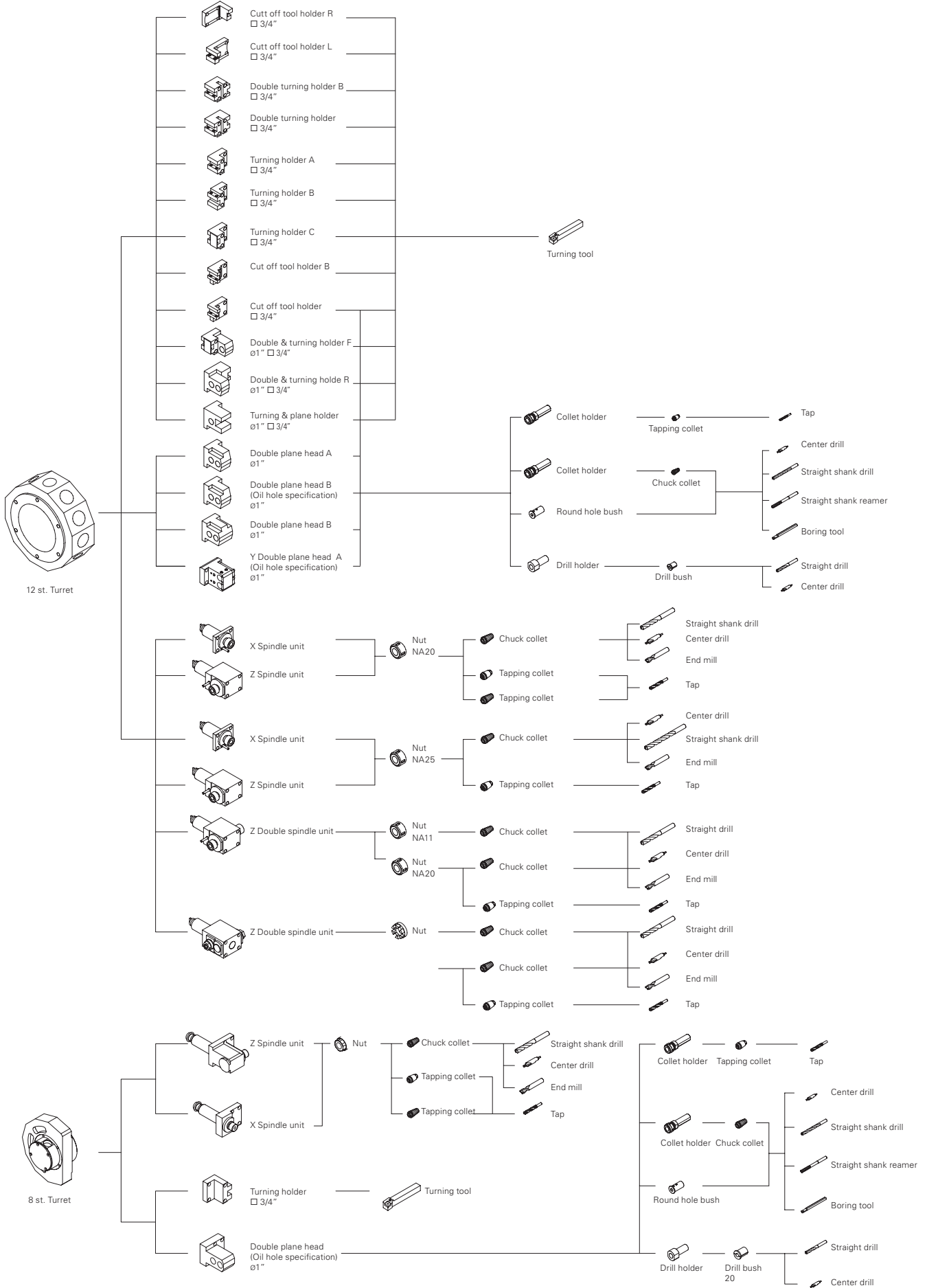



# Tooling Area

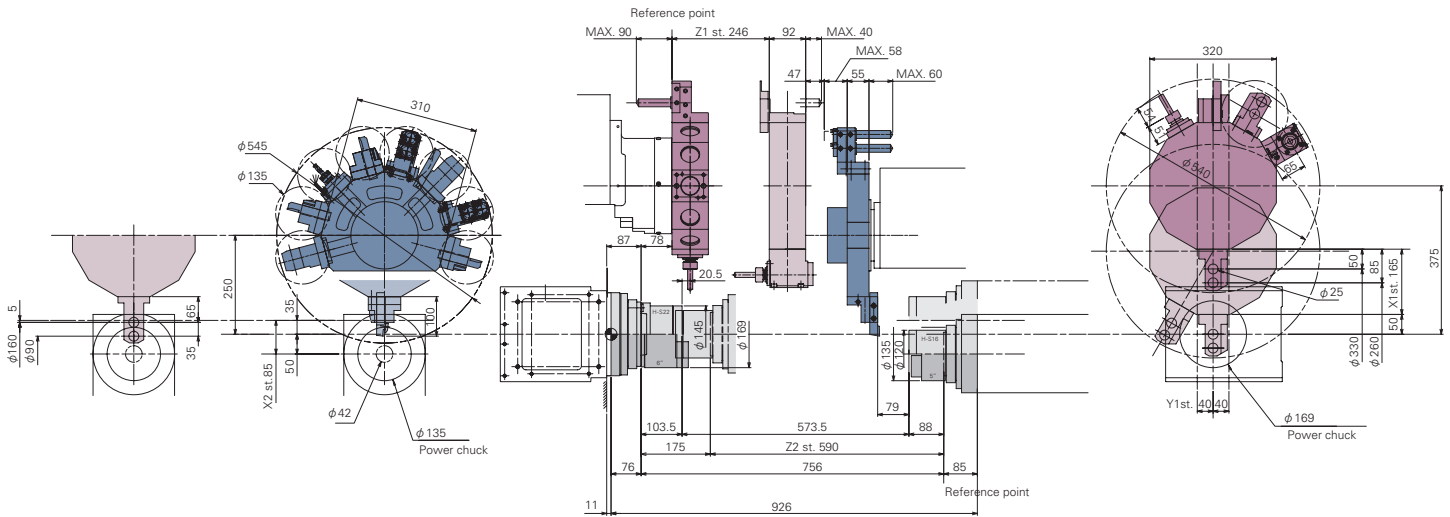

## Accessories



**Part catcher** (standard)  
The part catcher and part conveyor are indispensable for bar work.



**Part conveyor** (standard)



**Drill breakage detector** (option)  
Drill breakage is detected by the swing cylinder. The machine stops when breakage is detected, and a second accident can be prevented.



**Chip conveyor** (standard)  
This unit ejects chips smoothly and is indispensable for protracted, unmanned operation.

# Collision Buffering

When interference is encountered in rapid traverse operation, the function decelerates and stops axis feed and generates retraction torque to retract the feed axis in the opposite direction to the collision direction, limiting damage to the machine.

- \* This function does not serve to prevent collisions.
- \* It is only enabled for rapid traverse commands, and is disabled in cutting feed, etc.

Without the collision buffering function

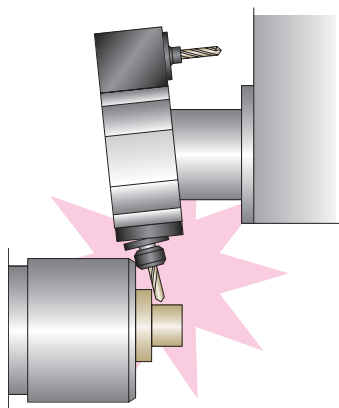

With the collision buffering function

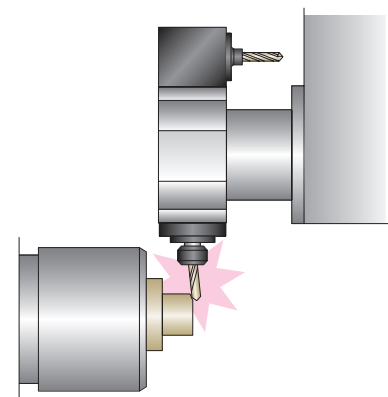

# Thermo Revision

The sensors installed inside this thermal displacement correction system measures the temperature of each part of the machine and corrects the thermal displacements on the X-axis and Z-axis by inputting coefficients prepared for oil-based and water soluble coolants.

Continuous cutting of brass No revolving tool operation (Thermo revision compensation ON)

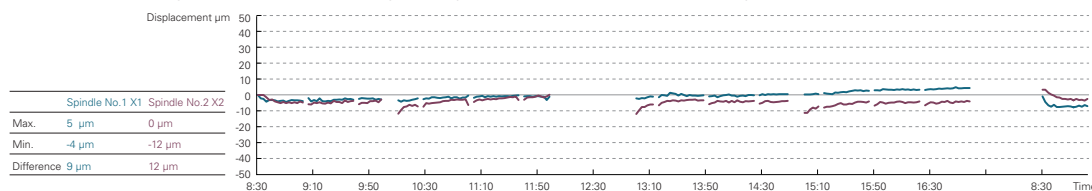
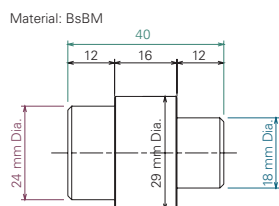

Continuous cutting of brass No revolving tool operation (Thermo revision compensation ON) Duty13%

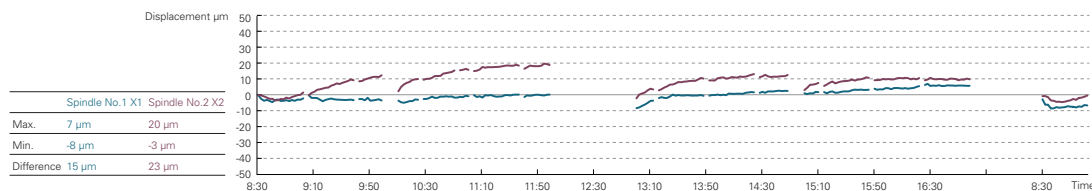

# Environmental Information

Basic Information	Energy usage	Power supply voltage	AC200V
		Electrical power requirement (Max)	33KVA
		Required pneumatic pressure	0.5MPa
Environmental Performance Information	Power consumption	Standby power <sup>1</sup>	4.843kW
		Power consumption with model workpiece <sup>2</sup>	0.0798 kWh/cycle <sup>3</sup>
		Power consumption value above converted to a CO2 value <sup>4</sup>	37.8 g/cycle
	Air consumption	Required air flow rate	max90Nl/min: during air blow
	Lubricant consumption	At power ON	6cc/15min
Noise level	Value measured based on JIS	78dB	
Environmental load reduction	RoHS Directive / REACH regulations	Compliant	
Approach to Environmental Issues	Recycling	Indication of the material names of plastic parts	Covered in the instruction manual <sup>5</sup>
	Environmental management		We are ISO14001 accredited. We pursue "Green Procurement", whereby we make our purchases while prioritizing goods and services that show consideration for the environment.

1. This is the standby power in the idle stop mode (a function that turns servomotor excitation off when it is not necessary, for example during program editing).
2. This is the power consumption in program operation (when not cutting) for one of our standard test pieces, shown for the purpose of comparing the environmental performance with that of existing models.
3. The average cycle time is 112.856 sec with the standard test workpiece of our company.
4. This is the value converted in accordance with the CHUBU Electric Power CO2 emissions coefficient for 2009 as published by the Ministry of the Environment.
5. If polyvinyl chloride (PVC) and fluoroc resin are not processed correctly they can generate harmful gases. When recycling these materials, commission a contractor that is capable of processing them appropriately.

# User Friendly Design for Ease of Operation

The operation panel that was at the top of the previous machines has been moved to the left side of the new SY6. Operating

convenience has been improved by lowering the position of the operation switches. The generous door opening also improves

access to the machining area, lightening the load on the operator.

Previous tooling area



New BNJ-51SY6 tooling area



# Machining Support Screens Provide Improved Working Efficiency

CUSTOM MENU	
NO.	NO.
1 BLOCK SKIP	9 AUTO MONITOR
2 MACHINING DATA	10 START CONDITION
3 TOOL SETTING	11 SPINDLE & RVT
4 TOOL COUNTER	12 POWER MONITOR
5 CYCLE TIME	13 MAGNETIC SWITCH
6	14 MAINTENANCE
7 COUNTER	15
8	16 TRANSFERENCE DET

BNJ-51SY6 DV5Y0002 DVES0001 (150423)

Menu screen

Displays the list of custom screens

HD1 TOOL COUNTER				
NO.	CURRENT	PRESET	X-WEAR	Z-WEAR
001	309	800	0.000	0.000
002	12	1000	0.000	0.000
003	0	0	0.000	0.000
004	500	500	0.000	0.000
005	0	0	0.000	0.000
006	0	0	0.000	0.000
007	0	0	0.000	0.000
008	237	2000	0.000	0.000
009	0	0	0.000	0.000
010	0	0	0.000	0.000

Tool counters

Used to set and reset the tool counter stop value and enter the tool wear offsets.

HD1 CYCLE TIME			
	Cutting	NotCutting	Operating
	225.392	122.704	348.096
1	0.000	18.896	18.896
2	0.000	0.000	0.000
3	0.000	0.000	0.000
4	0.000	0.000	0.000
5	0.000	0.000	0.000
6	0.000	0.000	0.000
7	0.000	0.000	0.000

Cycle time display

Measures the cutting time, non-cutting time and running time in each cycle.

HD1 MACHINING DATA	
PROGRAM NO.	550
CHUCK1 - CHUCK2 DISTANCE	400.000
CUT-OFF POSITION	5.000
WORK-PIECE LENGTH	50.000
CHUCK2 POSITION	20.000
TOOL OFFSET GEOMETRY R&W 1:ENABLE	<input type="checkbox"/>
ORIGIN SELECT FUNC 1:EFFEKTIVE	<input type="checkbox"/>

AFTER SELECTING TO VALID / INVALID, WILL REMEASURE THE TOOL OFFSET

Machining data

Entering the machining length and position of the cut-off here makes it easier to measure geometry offsets and to mount tools.

HD1 TOOL SETTING (GEOMETRY)					
NO.	X1	Z1	R	T	Y1
001	-223.020	98.626	0.000	0	0.000
002	-211.803	4.500	0.000	0	0.000
003	-260.000	81.291	0.000	0	0.000
004	-222.519	4.500	0.000	0	0.000
005	-200.415	4.500	0.000	0	0.000

MACHINE  
X1 -0.004 X2 -0.003  
Z1 130.551 Z2 -0.002  
Y1 -0.228

DRG SELECT

Tool setting

Used to measure geometry offsets. It can also be used for tool mounting support, to ensure that the overhang of all tools is fixed at a constant value.

T-MONITOR MONITORING No. 06								
%	25	50	75	100	125	150	PEAK	
X	*****					*	102	
Z	*							0
Y								
ZS								
C								
A								
S1	*****					*	98	
S2								

Tool monitor

Allows you to monitor tool wear and breakage by checking the current state of the machining and status of the cutting tools in terms of numerical values based on the sampling data.



# Machine Specifications

Model		BNJ-51SY6
Maximum machining length		100 mm
Diameter of standard cutting	Spindle No. 1	51 mm Dia.
	Spindle No. 2	42 mm Dia.
Chuck size	Spindle No. 1	6 inch
	Spindle No. 2	5 inch
Number of spindles		2
Spindle speed range	Spindle No. 1 & 2	5,000 rpm
Inner diameter of draw tube	Spindle No. 1	52 mm Dia.
	Spindle No. 2	43 mm Dia.
Collet chuck	Spindle No. 1	H-S22
	Spindle No. 2	H-S16, DIN171E
Power chuck	Spindle No. 1	6" thru-hole chuck
	Spindle No. 2	5" thru-hole chuck
Number of turrets		2
Type of turret	Turret No. 1	12 station turret
	Turret No. 2	8 station turret
Shank height of square turning tool		3/4" Sq.
Diameter of drill shank		1" Dia.
Revolving tools		
Number of revolving tool	Turret No. 1	Max. 12
	Turret No. 2	Max. 4
Type of revolving tool	Turret No. 1	Single clutch
	Turret No. 2	Simultaneous drive in all positions
Tool spindle speed range	Turret No. 1	6,000 rpm
	Turret No. 2	3,000 rpm
Machining capacity	Drill	Turret No. 1 Max. 13 mm Dia. Turret No. 2 Max. 10 mm Dia.
	Tap	Turret No. 1 Max. M12 × 1.75 (S45C-D) Turret No. 2 Max. M6 × 1.0 (S45C-D)
Turret slide stroke	X1 axis	165 mm
	Z1 axis	246 mm
	Y1 axis	80 (± 40) mm
Spindle slide stroke	X2 axis	85 mm
	Z2 axis	590 mm
Rapid feed rate	X1, Z1, X2, Z2 axes	20 m/min
	Y1 axis	12 m/min
Motors		
Spindle drive	Spindle No. 1 Cs	15/ 11 kw (15 min/cont.)
	Spindle No. 2 Cs	7.5/ 5.5 kw (15 min/cont.)
Revolving tool drive	Turret No. 1	2.2 kw
	Turret No. 2	0.75 kw
Slide		1.2 kw (X1, Z1, Y, X2, Z2)
Hydraulic oil motor		2.2 kw
Lubricating oil motor		0.004 kw
Coolant pump		0.25 kw × 1, 0.18 kw × 1
Turret index motor		0.75 kw
Power supply		
Voltage		AC 200/ 220 ±10% 50/ 60 Hz ±1%
Capacity		33 KVA
Air supply		0.5 MPa
Fuse		100 A
Hydraulic oil tank capacity		10 L
Lubricating oil tank capacity		4 L
Coolant tank capacity		300 L
Machine height		1,700 mm
Floor space		2,630 × 1,540 mm (without chip conveyor)
Machine weight		11,687 lbs

NC Device	Fanuc FS 0i-TF
Controlled axis	Simultaneously controlled axis Max.4 X1, Z1, Y1, Cs1, A1, A2, X2, Z2, Cs2
Min. input increment	0.001 mm, 0.0001 inch, 0.001 deg
Min. output increment	X axis: 0.0005 mm, Z axis: 0.001 mm Y axis: 0.001 mm
Parts program storage capacity	Total 1MB (2,560m Tape length)
Spindle function	Spindle speed S4-digits Constant Cutting speed control (G96)
Rapid traverse rate	X1, X2, Z1 axis: 20 m/min Z2 axis: 20 m/min Y1 axis: 12 m/min
Cutting feed rate	F 3.4 digit per revolution
Cutting feed rate override	0-150% (in 10% increments)
Interpolation	G01, G02, G03
Threading	G32, G92
Canned cycle	G90, G92, G94
Work coordinate setting	Automatic Setting, 64 work coordinate setting by the tool position
Tool selection	by TAABB at the specified position for each turret tool wear compensation is selected by BB.
Direct input of tool position	by measured MDI
Input/ Output interface	USB, PC Card slot
Automatic operation	1 cycle operation/ Continuous operation, Single block Block delete, Machine lock, Dry run, feed hold Optional block skip

## NC standard functions

10.4" color LCD  
No of resistered programs: 800  
Decimal point input  
Manual pulse generator  
Memory protect  
Polar coordinate interpolation  
Programable data input (G10)  
C-axis control (SP1/SP2)  
Superimposed control A  
Chamferring/ Corner R  
Tool nose R compensation  
Background editing  
Synchronous mixed control  
Operating time/ Parts No. display  
Multiple repetitive canned cycle (G70-G76)  
Continuous threading  
Canned cycle for drilling  
Tool life management system  
Variable-lead cutting  
Rigid tap function (Spindle & Revolving tool)  
Circular interpolation  
Custom macro  
Handle retrace function  
Polygon cutting  
Synchronized function  
Dual check safety  
Network I/O function  
Reference position setting  
Helical interpolation, RS-232C

## Others

Splash guard interlock  
Coolant  
Pneumatic unit  
Machine light  
Non-fuse breaker  
SP2 Work ejector & inner high pressure coolant  
Chuck close confirmation  
Total & preset counter (Custom menu)  
Cut-off confirmation  
High pressure coolant  
Revolving tool (HD2)  
Spindle brake  
Air blow  
Parts catcher & Parts conveyor  
Chip conveyor  
Coolant level switch  
Bar feeder interface  
Signal tower  
Automatic power shut-off  
Thermo revision

## Optional accessories

Drill breakage detector  
Part carrier  
Chip box  
Tool holder, tools, etc.

# Marubeni Citizen-Cincom Inc.

40 Boroline Road  
Allendale, NJ 07401  
201-818-0100

2316 Touhy Avenue  
Elk Grove Village, IL 60007  
847-364-9060

17815 Newhope Street, Suite P  
Fountain Valley, CA 92708  
714-434-6224

68 Moylan Lane  
Agawam, MA 01001  
413-786-6655

[www.marucit.com](http://www.marucit.com)